

MGA-718544-HP3 7.1 – 8.5 GHz 25W GaN Power Amplifier

Features:

- 12 dB Gain
- 44 dBm and LSG ≥ 7.0 dB CW
- OIP3 ≥ 54 dBm at 38 dBm per tone
- PAE 32% at 44 dBm
- Matched Input and Output for Easy Cascade
- Surface Mount Package with RoHS Compliance
- Thermal Resistance is 2.0°C/W
- MTTF > 100 years @ 85°C ambient temperature

Applications:

- Point-To-Point Radio
- Wireless Connectivity

Description:

MwT's MGA-718544-HP3 is a 25W GaN power amplifier. Operating from 7.1 to 8.5 GHz, the amplifier's CW RF power output is 25W typical and PAE of 32%. The amplifier's RF input and output are matched to 50 Ω . External bias tees are required. The OIP3 is 54 dBm (38 dBm per tone).

The MGA-718544-HP3 packaged base is a solid copper offering superior thermal management. The overall Rth is 2.0°C/W.

Typical RF Performance: $V_{ds}=28V, V_{gs}=-2.27V, I_{dq}=300mA, T_a=+25^\circ C(2), Z_0=50\ ohm$

Parameter	Units	Typical Data
Frequency Range	MHz	7100-8500
Gain (Typ / Min)	dB	13.5 / 11
Gain Flatness (Typ / Max)	+/-dB	1.0 / 1.5
Input Return Loss	dB	4.5
Output Return Loss	dB	6.0
Output P3dB	dBm	44.0
OIP3(1)	dBm	54
Operating Current Range	A	2.4
Thermal Resistance	°C /W	2.0

(1) Output IP3 is measured with two tones at output power of 36 dBm/tone separated by 10 MHz.

MGA-718544-HP3

7.1 – 8.5 GHz
25W GaN Power Amplifier
Data Sheet

Typical RF Performance: $V_{ds}=28.0V$, $I_{dq}=250mA$ $Z_0=50\ ohm$, $T_a=+25\ ^\circ C$

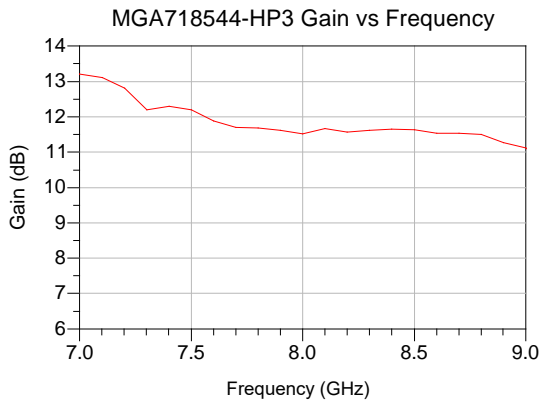

Figure 1 MGA718544HP3 Gain Response

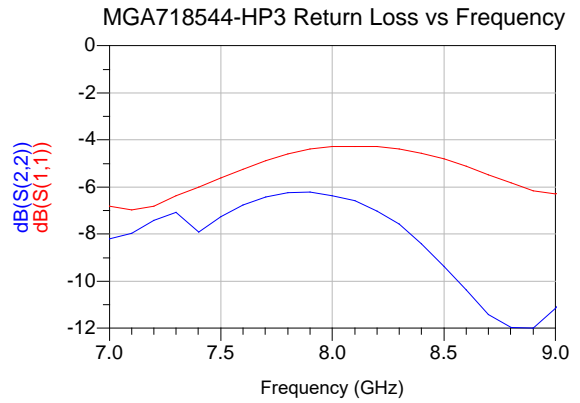

Figure 2 MGA718544HP3 Return Loss

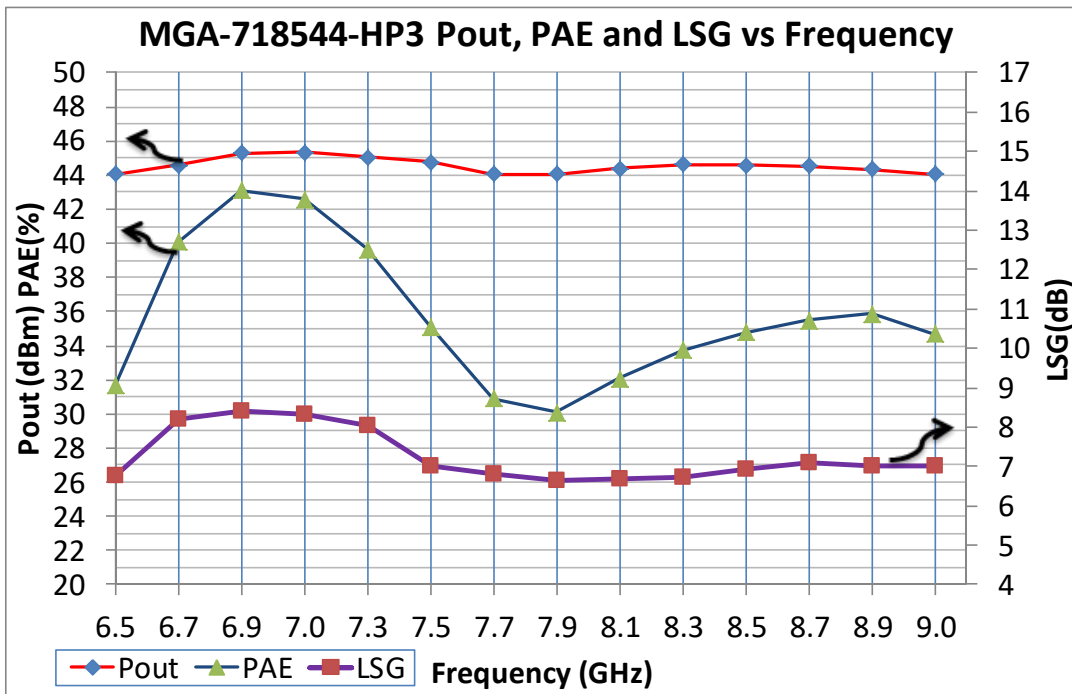

Figure 3 Typical RF Power (CW) Performance $V_{ds}=28V$, $I_{dq}=300mA$

MGA-718544-HP3

7.1 – 8.5 GHz
 25W GaN Power Amplifier
 Data Sheet

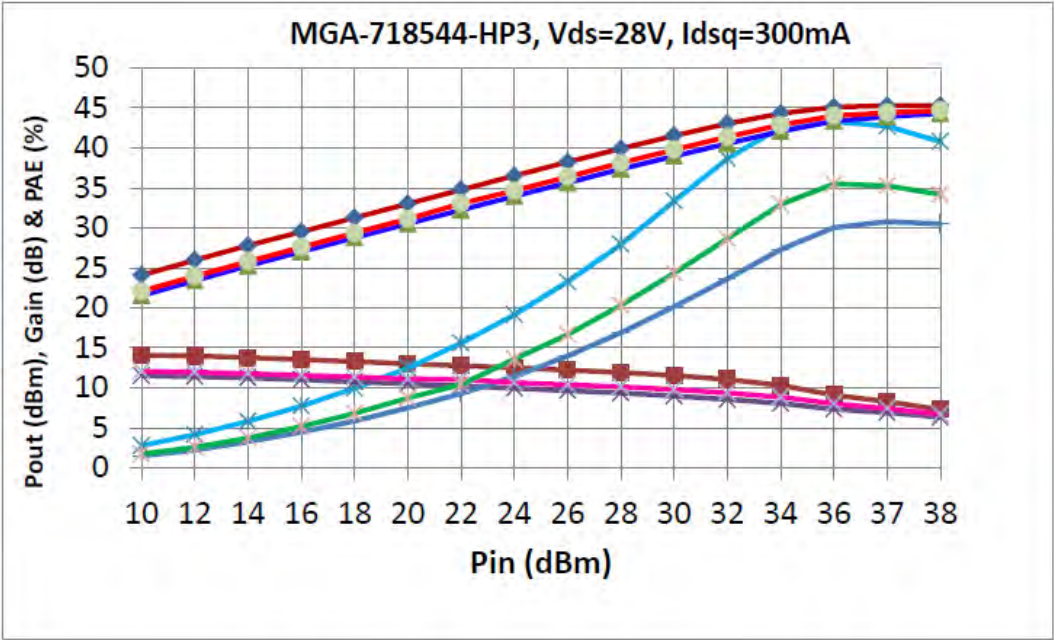

Figure 4 Pout, Gain, and PAE vs Pin

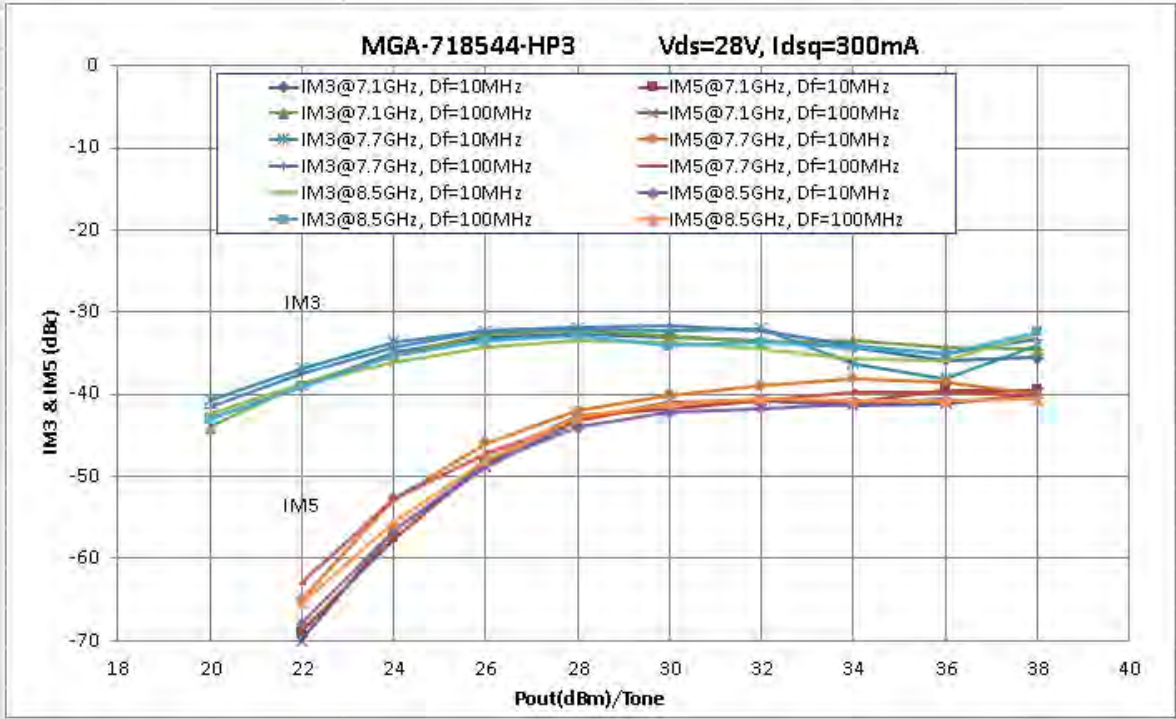
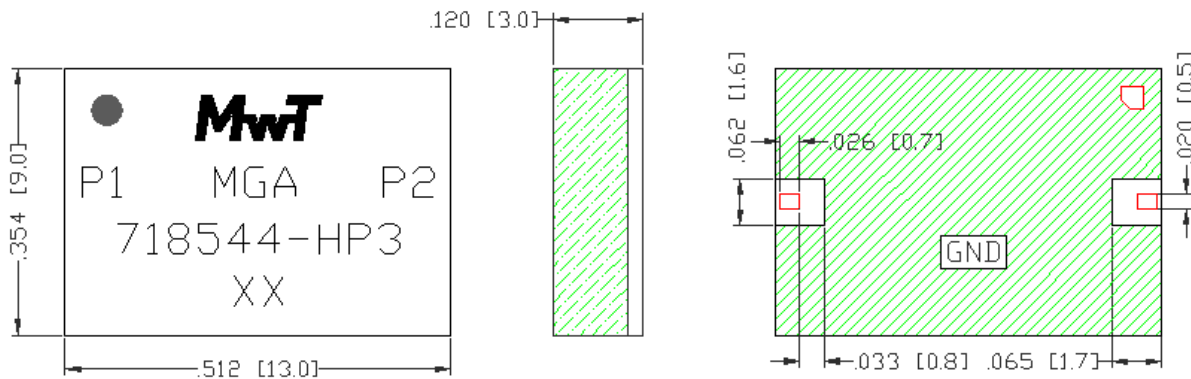

Figure 5 IMD3 and IMD5 vs Power per Tone Vdd=28V Idq=300mA

MGA-718544-HP3

7.1 – 8.5 GHz
25W GaN Power Amplifier
Data Sheet

Mechanical Information: *This Package is RoHS compliant*



Pin	Functions
1	RF in, Vgs feed in
2	RF out, Vds feed in
GND	The GND area of the bottom should be thermally and electrically grounded

Absolute Maximum Ratings: ($T_a = 25\text{ }^\circ\text{C}$)*

SYMBOL	PARAMETERS	UNITS	ABSOLUTE MAXIMUM
Vds	Drain-Source Voltage	V	29
Id	Drain Current	mA	5500
Ig	Gate Current	mA	3.0
Pdiss	DC Power Dissipation	W	83
Pin max	RF Input Power	dBm	+38
Tch	Channel Temperature	°C	225
Tstg	Storage Temperature	°C	-55 to 125

*Operation of this device above any one of these parameters may cause permanent damage.

MGA-718544-HP3

7.1 – 8.5 GHz
25W GaN Power Amplifier
Data Sheet

Application Circuit and Board Design

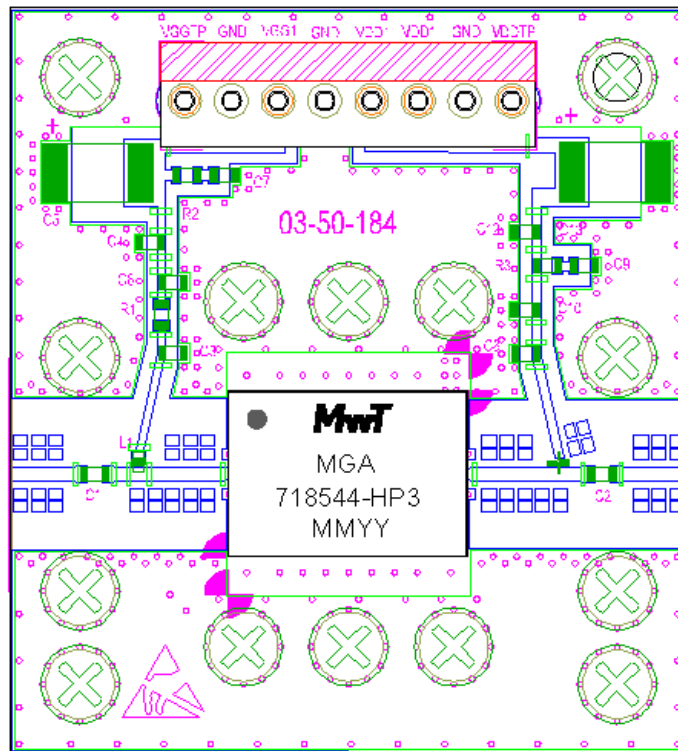
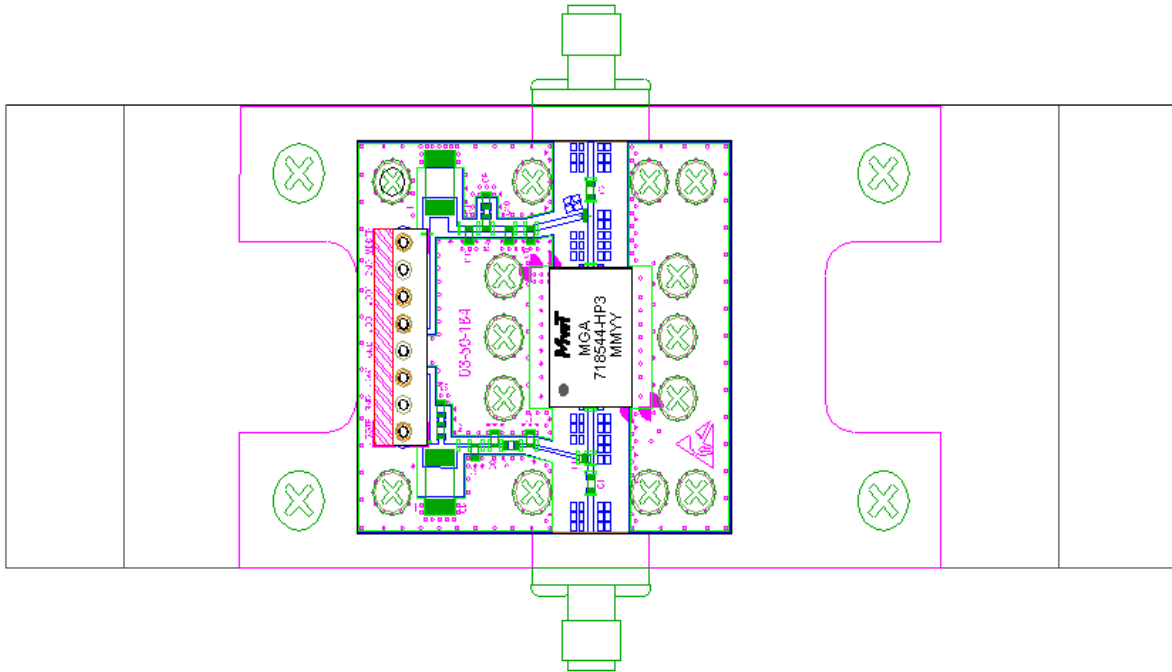

MGA-718544-HP3

7.1 – 8.5 GHz
25W GaN Power Amplifier
Data Sheet

Item	Quantity	Description	Vendor P/N	MwT P/N	Ref No.
		HP3 25 Watt AMPLIFIER	MGA-718544-HP3		
1	1	MGA-718544-HP3		01-31-043	
2	1	CONNECTOR, 8 PIN	640456-8		P1
3	1	COVER		04-071037	
4	1	COIL 3 TURN	3-5038-A	03-02-307	L2
5	1	COIL 6.8nH	0402DC-6N8X-R	03-02-302	L1
6	4	CAPACITOR .1 uF	GRM155R61H104KE19D	03-02-306	C6,7,9,12
7	1	CAPACITOR 1000 pF	C0603C102K5RACTU	03-02-305	C4, 10
8	4	CAPACITOR 2 pF	ML03512R08AT2A	03-02-304	C1,2,3,8
9	2	CAPACITOR 1.0 uF	T491C105K050AT	03-02-004	C5,C13
10	2	RESISTOR 51 OHMS	ERJ-2GEJ510X	03-02-307	R1,2,3
11	1	PALLET MOUNT		04-20-415	
12	1	HEAT SINK		04-20-405	
13	4	SCREWS 4-40, PHD PHIL			
14	14	SCREWS 2-56, PHD PHIL			
15	A/R	SOLDER 60/40		06-08-001	

Electrical Schematics

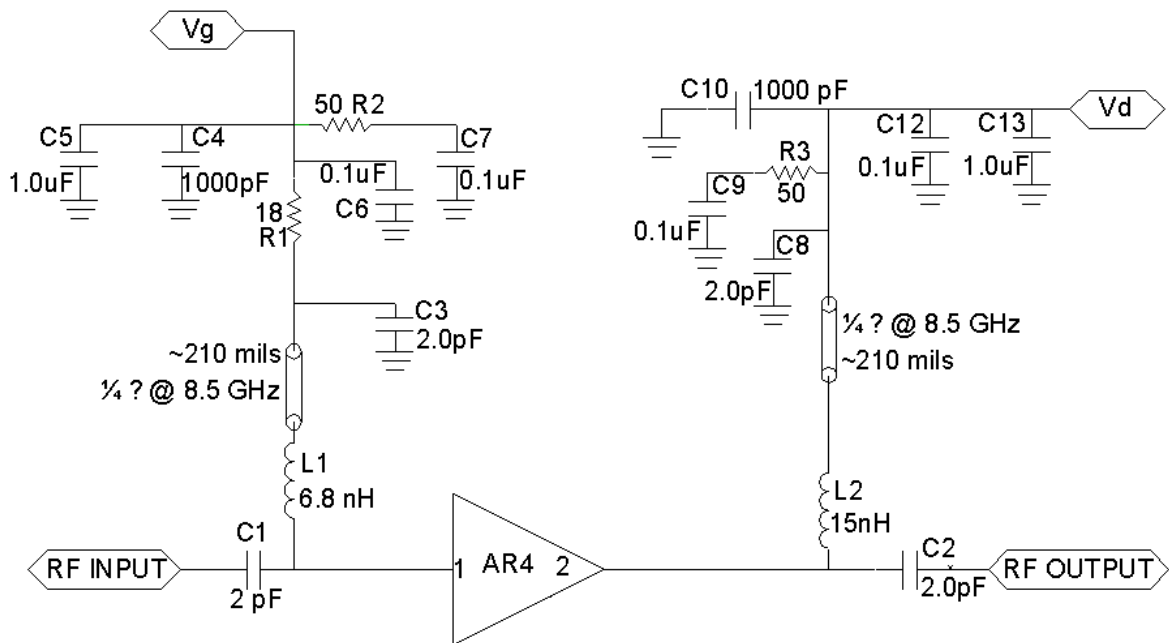

MGA-718544-HP3

7.1 – 8.5 GHz
25W GaN Power Amplifier
Data Sheet

Contact Information

For additional information please visit www.cmlmicro.com or contact a sales office.

Europe	America	Asia
<ul style="list-style-type: none">• Maldon, UK• Tel +44 (0) 1621 875500• sales@cmlmicro.com	<ul style="list-style-type: none">• Winston-Salem, NC• Tel +1 336 744 5050• us.sales@cmlmicro.com	<ul style="list-style-type: none">• Singapore• Tel +65 6288129• sg.sales@cmlmicro.com

Although the information contained in this document is believed to be accurate, no responsibility is assumed by CML for its use. The product and product information is subject to change at any time without notice. CML has a policy of testing every product shipped using calibrated test equipment to ensure compliance with product specification.

© 2020 CML Microsystems Plc